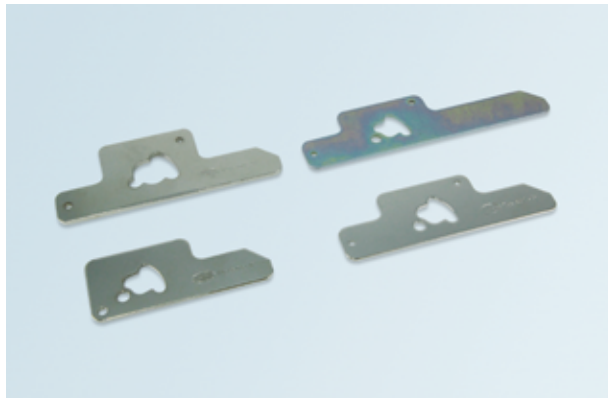

TO-300 / TO-301 / TO-302

止め金具

Cam (Optional)

**特長**

ハンドル用止め金具です。

用途

THA-408AN / THA-540 等

Characteristic

Cam for handles

Application

THA-408AN / THA-540, etc.

材質と処理 Material & Finish

材質 Material	処理 Finish
SPCC	Ni・3価クロメート Trivalent Chromate Treatment

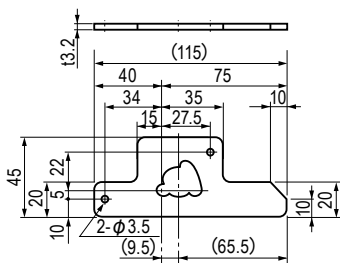
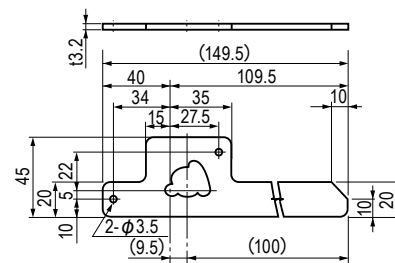
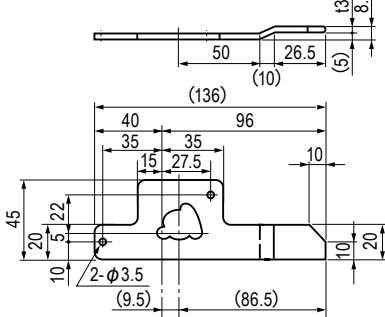
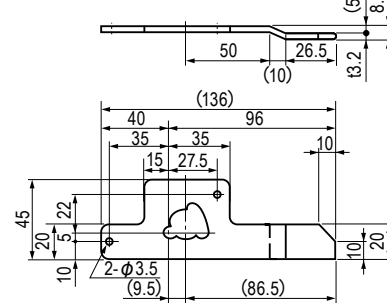
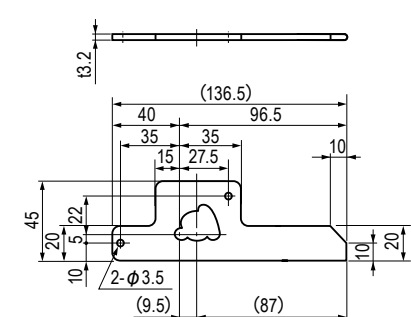
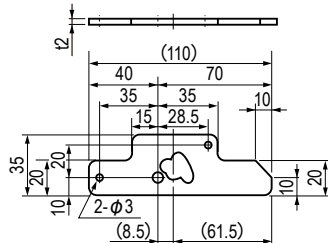
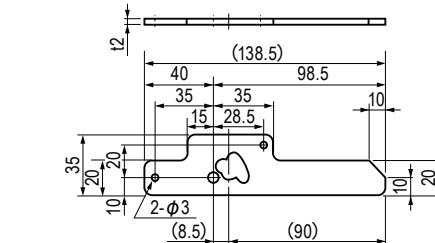
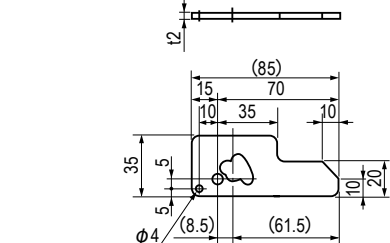
TO-300-0**TO-300-1****TO-300-3****TO-300-4****TO-300-5****TO-301-0****TO-301-1****TO-302-0****仕様 Specification**

型番 Model No.	適用型番 Applicable Model No.	自重 (g) Net Weight (g)
TO-300-0	THA-408AN-1・1K THA-540-1・1K	78
TO-300-1		92
TO-300-3		86
TO-300-4		
TO-300-5		
TO-301-0	THA-408AN-2・2K、3・3K THA-540-2・2K、3・3K	42
TO-301-1		51
TO-302-0		34

特注品のご相談承ります Please contact us for custom-made.

3

ハンドル
Handle取手
Pull握り手
Pull握りハンドル
Gripsハンドル
Handles付属部品
AccessoriesEMKAハンドル
EMKA Handles